

# The Reflecting Telescope

Lens telescopes exist since 1609 when the Dutch maker of spectacles, Jan Lippershey, sold the first telescopes, then as a curiosity, to his astonished customers. It was made out of a concave and a convex lens, produced an upright standing image and had a 3 1/2 times magnification. Galileo Galilei (1564-1642) improved on this invention and was the first to make astronomical observations with it. Today almost all lens telescopes are built according to the principles of Johannes Kepler (1571-1630). His telescope, based on two convex lenses, produced an upside down but much bigger and better focused image which of course for observing the heavens are the most important factors. Building larger telescopes however brings two problems with it: Firstly, in a lens the light rays are broken, as in a prism. That can lead to colour distortion and poor focus and can only be corrected with great expense. Secondly, the bigger the telescope, the heavier the lens and as a result the more difficult it is to handle.

Isaac Newton (1643-1727), natural scientist and mathematician, was aware of this problem and solved it in 1668 by inventing a telescope in which the lens was replaced by a concave mirror. The light was now gathered, reflected and then directed sideways to an eyepiece by a small flat slanted mirror. Newton's first mirror, which he built himself with his own special tools, had diameters of 25 and 50mm, a focal length of 300mm and a 30 times magnification. Thus the groundwork was laid for a whole new generation of telescopes. Today almost all large telescopes, including the Hubble space telescope, are built according to Newton's invention.

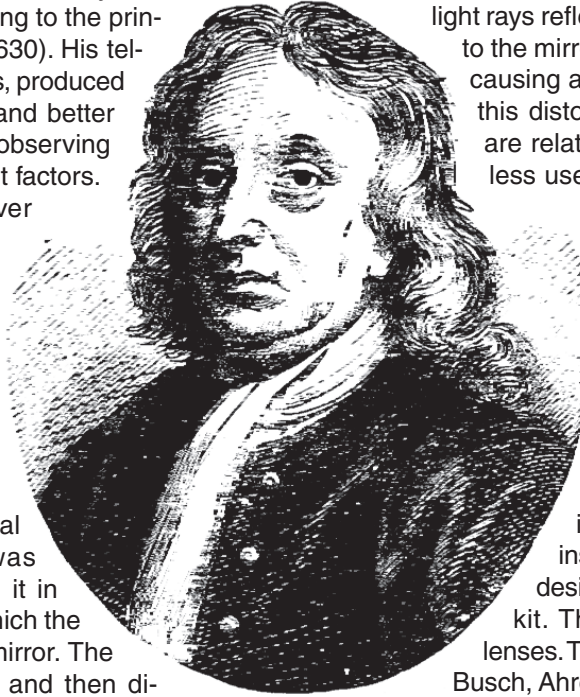

The optical properties data of the AstroMedia\* reflecting telescope roughly correspond to those of the first instrument built by Newton. The mirror has a focal length  $f=450\text{mm}$  ("f" from the Latin "focus" is the abbreviation of focal length). Its curve is spherical, i.e. it has the same round surface as a globe.

A spherical concave mirror has one disadvantage: the light rays reflected from the edge meet a little nearer to the mirror than those reflected from the centre, causing a slight focus distortion. However, since this distortion is not grave and such mirrors are relatively easy to grind, they are nevertheless used in smaller telescopes. In telescopes with larger openings and stronger magnification mirrors with parabolic curves are used. These are of course more difficult and expensive to produce, but the result is that all the light rays meet at one point.

The main mirror of this kit is made of ground and polished glass and has a coating of vaporized aluminium. A product of BAADER Planetarium, leading German suppliers of astronomical instruments, the mirror has been specially designed and produced for this AstroMedia\* kit. The eyepieces are made with acrylic lenses. Thanks to the friendly advice of Wolfgang Busch, Ahrensburg, an arrangement of lenses was found which reduces distortions and colour shifts to a very high degree. A cardboard telescope can, of course, never compete with factory made instruments made from massive materials, but this kit gives you the possibility of following in Newton's footsteps and in the end you will be just as surprised with the result as Newton was with his first reflecting telescope.

## Tips for successful construction

1. Please read the instructions for each step completely before beginning and allow yourself enough time. You will be rewarded with a more beautiful and accurate reflecting telescope.
2. Before removing any pieces, cut the little joints that hold them in place with a sharp knife, e.g. with the AstroMedia\* handcraft knife (Nr. 404.MES.) Only remove the piece that you currently need.
3. There will be a groove wherever the card needs to be folded. The grooves will sometimes be folded to the back and sometimes to the front. "Fold to the back" means folding away from oneself when facing the groove. "Fold to the front", means folding towards oneself. After folding, smooth the fold with the back of your thumbnail to make it lie flat.
4. As a rule the areas to be glued are marked in grey on the front of the card sheets. Use a good solvent based all-purpose glue which has the advantage over water based glues that it doesn't distort the paper and it dries faster.
5. If you want small pieces to dry faster, coat one side generously with glue, press the two surfaces together so that the glue is transferred to both surfaces, pull apart and blow two or three times on the glue until almost dry then press the two parts together accurately and firmly. The glue will stick immediately. It is better to avoid this method with the mirrors and lenses as the glue can leave strings on the surface.
6. You also need some sticky tape, a scissors, a pair of medium rubber bands, 2 pairs of paper clips and about 10 strong clothes pegs. For fine

adjustment of the main mirror you need a set-square or a ruler, a thin felt-tip pen that can write on glass as well as a mirrored glass ball (for example a Christmas tree decoration).

7. If you are a perfectionist you can blacken the white cut edges of the diaphragms, lens holders etc.) with a black felt pen before fitting them.
8. After the glue has dried you can rub down the protruding edges with emery paper or a fine file, e.g. the AstroMedia\* handcraft file (Nr. 400.SBF).
9. Advice on the mirrors: The main and the secondary mirrors are coated on the front surface with a vapour-deposited aluminium film which, despite a protective quartz film, makes them much more delicate than rear silvered mirrors. Avoid touching the mirrored surfaces with your fingers and, if necessary, clean them only with a lint free cloth and alcohol. The aluminium film of the small rectangular secondary mirror is covered by a protective foil. This foil will not be removed until after construction.
10. Special note for those experienced in handcraft: It is possible to make the mounting of the telescope even more stable by cutting, to a perfect fit, some stiff card, to be placed between some of the card parts in this set. Among these included are the parts [C3]+[C4], [C5]+[C6], [H1]+[H2], [J1]+[J2] (the size of [J2] without foot tabs) and [J3]+[J4] (the size of [J4]. However you must bear in mind that the size of the bridge-piece [J5] and the glue markings on the base plate [H1] are in relation to the normal thickness of the walls.

# Instructions:

## The Main Body and the Eyepiece Connector

*The tube is the actual reflecting telescope. The large main mirror sits inside one end and in the opening at the other end the small right angled collecting mirror reflects the focused image from the main mirror at a right angle into the eyepiece. The tube is made up of two larger and two smaller segments which are connected by the extended gluing tabs of the three internal diaphragms.*

**Step 1** The axle segment [A1] is one of the two large segments onto which you will later glue the axle which allows the tube to move up and down. Remove the axle segment from the card sheet and fold all the grooves to the back. Glue the long glue tab behind the opposite edge so as to form a hexagonal tube.

**Step 2** The sight segment [A2] is the second large segment. The rear sight [G3] and [G4] will later be glued onto it. Fold and glue it together like the axle tube.

**Step 3** Remove the round cardboard piece from the three internal diaphragms [A3], [A4] and [A5]. Each tab around the hexagon has a white marked line in the middle of its grey front surface. Fold the tabs backwards so that the side with the white line is on the outside and the black side is on the inside.

**Step 4** Put one of the hexagonal internal diaphragms into the end of the axle segment (first without glue) which has *"hier stößt die Markierung -111- des Visiersegments an"* and push the diaphragm into the hexagonal tube so that the marked lines on the six tabs lie exactly on the edge of the tube. Now all the tabs stick half-way out of the opening of the axle segment. Glue it in this position by pulling it out, coating the inside of the tube with glue, reinserting the diaphragm and pressing the tabs firmly into place.

**Step 5** Wait until the glue is dry and then make a trial run (without glue) by placing the sight segment [H2] over the tabs of the diaphragm so that the instruction *"Markierung -111-"* lies directly next to the instruction *"hier stößt die Markierung -111- des Visiersegments an"*. Now remove the sight segment and coat the inside at the appropriate end with glue and assemble it onto [A1] with the tabs inside. Important: Make sure the two tubes butt directly against each other with no gap. Press the tabs firmly into place from inside until they are stuck. Stand vertically with a light weight on top until the glue is dry.

**Step 6** Glue the other 2 internal diaphragms into the ends of the assembled tube in the same way as the first with the line of the tab protruding half-way out of the tube.

**Step 7** The main mirror will later be set in the mirror segment [A6] and the front sight [G1]+[G2] will later be placed on this segment. Fold the mirror segment and glue it to form a short hexagonal tube which has the same diameter as the already existing tube comprising the sight segment and the axle segment.

**Step 8** Glue the mirror segment [A6] to the tabs protruding from the end of the axle segment making sure that the *"-222-"* markings line up and that there are no gaps or cracks between the segments.

**Step 9** Remove the centre hexagonal area where the eyepiece goes from the eyepiece segment [A7]. Fold and glue the segment to form a hexagonal tube. Do not attach it to the rest of the body yet.

**Step 10** Fold the five longer grooves of the eyepiece connector [B1] to the back to form a short hexagon. This will not be formed into a hexagon with glue but with sticky-tape from the inside. The tape should only connect the edges of the tube and not the tabs. Place half the width of the tape on one edge of the tube and then press the other edge on the protruding length of tape. Be careful that the eyepiece connector is not too tight for the eyepieces. To be absolutely sure you can first complete steps 32 and 39 by gluing the eyepiece shafts [F1] and [F5] to test if they can move up and down on the eyepiece connector without too much trouble. It may be that you have to cut the tape and renew it. Fold the foot tabs outwards, i.e. not to the inside of the tube.

**Step 11** Insert the eyepiece connector through the hexagonal hole in the eyepiece segment [A7] from the inside. Important: Make sure the two diagonally cut tabs are on the side *away* from the *"-333-"* marking, i.e. towards where *"hierhin kommt die Öffnungsblende"* is printed. This is to ensure the secondary mirror holder [D1] can be glued correctly in place later. When you are sure you know which way round it goes, remove it, glue the foot tabs and reinsert it, pressing the tabs firmly until stuck. You can do this by laying the entire segment flat and pressing on the tabs from outside. Make sure the eyepiece tube is at right-angles to the main tube. Check with a set square or the corner of one of the card sheets.

**Step 12** Fold the long groove of the lower eyepiece connector collar [B2] to the front and the five short grooves to the back. The result is a chain of 6 joined links each of which has an adjoining section. Place this chain around the eyepiece connector so that the split sections are lying flat on the tube of eyepiece segment and glue it in this position. Fold the grooves of the upper

eyepiece connector collar [B3] to the back and glue it around the opening of the eyepiece connector.

**Step 13** Put the eyepiece segment [A7] with the assembled eyepiece connector onto the remaining tabs on the main body making sure that the markings *"-333-"* line up. (The diagonal tabs on the eyepiece connector point to the front opening of the main body). Glue in place as before making sure that the two tubes butt directly against each other with no gap. Press the tabs firmly until stuck.

**Step 14** Cut-out the 3 body collars [A8], [A9], [A10]. Glue into place around the main body joints, wherever two segments meet.

**Step 15** Glue the axle disks [C3] and [C4] together to make a double thickness disc. Make sure the edges are properly aligned otherwise you will need to sand them to a round shape when dry. Repeat with the other pair [C5] and [C6].

**Step 16** Stick the right double-layered axle block exactly in the middle of the right axle base [C1], the left, on the left axle base [C2]. To ensure they are central you can stick a pin through the marks in the middle of the axle blocks and bases. Leave until dry.

**Step 17** Stick the resulting unit of right axle base and block with the unprinted side exactly in the middle of the corresponding markings on the axle segment of the tube. Do the same with the left.

**Step 18** Coat the right axle block with glue and stick the right axle cover disc [C7] onto it. The zero degree mark "0" should be exactly over the small white arrow at the edge of the tube side and the negative number *"-80"* should be towards the eyepiece tube. Between the axle base and the cover disc you now have a slot into which later the arms of the axle bearings at the top of the two mounting supports will be fitted. Repeat the procedure with the left axle cover disc [C8] correspondingly.

*The tube is now finished and ready for the optical elements to be fitted.*

## The Secondary Mirror

*The 15,5x22mm secondary mirror directs the light rays from the main mirror at a right angle into the eyepiece. It needs to be held exactly central in the main body at 45 degrees to its axis and directly under the eyepiece connector. Therefore it is particularly important to fix the mirror mounting plate [D1] carefully.*

**Step 19** Fold the main part of the secondary mirror mounting [D1] along the long groove to the back so that the two unprinted halves are joined flush on each other. Fold the two small rectangular, slanted tabs to the front as well as the two wide foot tabs and the two narrow head tabs. Glue the main part carefully together making sure there is no glue on the tabs. Press the main part, while drying, so that it remains straight.

**Step 20** Fold the two small diagonal tabs away from each other so that they form a right angled plate for the secondary mirror that is at 45 degrees to the folded back of the mirror holder. Glue the mirror in place, on the non-film side, ensuring that as it dries the tabs on which the mirror is glued do not bend to one side or the other but remain at right angles to the mirror holder. The mirror is covered with a bluish protective film which should only be removed after the glue is dry. Lift one corner of the film with a craft knife and carefully peel it off.

**Step 21** Fold the two wide foot tabs and the two narrow head tabs away from each other and try the mirror holder in the eyepiece end of the main body. Don't glue it at this stage. The mirror must point into the main body. The head

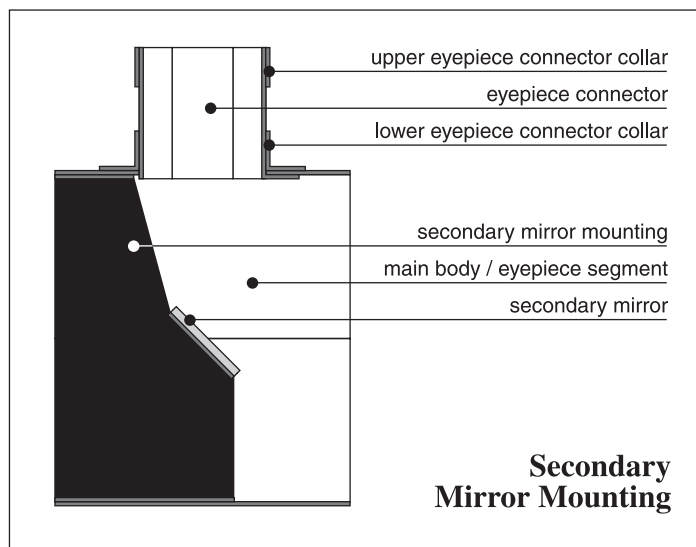

tabs of the mirror holder sit on the eyepiece side of the main body and cover the whole width of the face of the tube. The two foot tabs sit similarly on the opposite face. Push the mirror holder in until it is flush with the end of the main body and secure the tabs with 4 paper clips.

**Step 22** Now look through the eyepiece connector. Because of the diaphragms you should see a circular image through the other end of the telescope. This circular image should be in the middle of the secondary mirror. If the image is off to one side or the other, a slight pressure on the mirror in the other direction should be sufficient to correct this. Luckily cardboard is a very forgiving, error tolerant material... Do not stick the mirror holder in place yet.

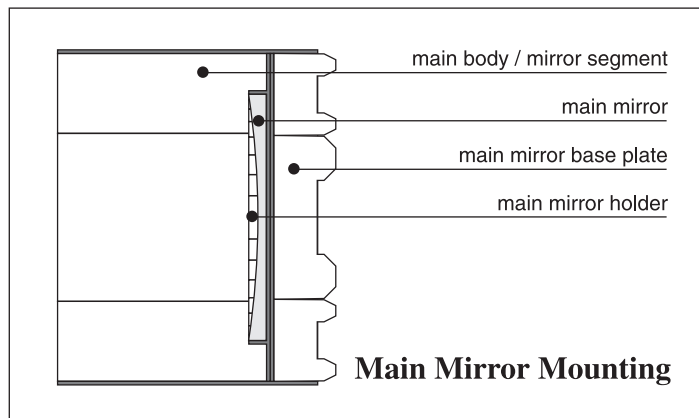

## The Main Mirror

The main mirror has a 450mm focal length (abbreviated to "f" from the Latin focus). That means it focuses parallel light to a point 450mm from its surface. That would be about 28mm in front of the end of the main body if the secondary mirror had not diverted the light sideways into the eyepiece. The following steps should be done carefully and slowly. The front surface of the mirror is very susceptible to scratches and glue threads, despite the protective vapour-deposited quartz layer on top of the aluminium.

**Step 23** Fold the six tabs of the main mirror base plate [E1], to the back. At the corners of each tab there are small handles. These are to facilitate adjustment of the mirror and are only cut-off later after successful set-up.

**Step 24** Fold the 36 small tabs of the main mirror holder [E2] to the front and make sure that the narrow hexagonal surround is not bent. Glue this hexagonal surround centrally onto the base plate [E1]. The tabs should not have any glue on them. Press the piece flat until dry.

**Step 25** Fold the tabs completely up so they form a sort of round fence, apply glue to the inside edge as well as to the round inside of the base, and insert the main mirror with its flat unsilvered side down. Only hold the mirror by its edges and don't touch the silvered surface. Apply a light tension with a rubber band around the ring of tabs so they are pressed on evenly and lightly. Put the whole assembly on a flat surface and apply a light pressure until dry. Put a cloth between the mirror and any weight. It is important that the mirror lies flat and even on the card. **Allow to dry completely before moving it.** Small amounts of adhesive at the edge of the mirror do not affect the optics as a 5mm band around the edge is not used optically.

**Step 26** It is necessary for the adjustment to draw a small cross exactly in the middle of the main mirror. The optical quality does not suffer because of this mark because the secondary mirror keeps the light from falling onto the centre region of the main mirror anyway. Measure exactly the centre point with a set-square or a ruler and mark it with a thin felt-tip pen.

**Step 27** Insert the main mirror holder assembly without any glue from the back into the main body, mirror first. Push it in until the tabs are flush with the end of the body and only the adjusting handles are sticking out. The main mirror is now roughly pre-adjusted. Secure the tabs temporarily in place with 6 paper clips or wash pegs.

**Step 28** Make sure the telescope opening is not pointed at the sun and look into the eyepiece connector. Light from the front opening of the telescope is now reflected by the main mirror. In the middle of this circular patch of light you can see the secondary mirror, which appears to be square as it is tilted at 45 degrees.

## The Basic Adjustment

For terrestrial observations by day as well as observing the moon's craters or sunspots on the sun the following steps are normally sufficient. (Important: You must use a sun filter to look at the sun.) With some luck it will also be good enough for the observation of point light sources at night, such



as Jupiter's moon, so that the fine adjustment (step 56) can be skipped.

**Step 29** Look through the eyepiece connector at the secondary mirror. If construction was perfect, the main mirror will appear as a perfect round shape with the square secondary mirror in its centre. Now move your eye back to a point where the secondary mirror appears to completely fill the opening of the eyepiece connector. Keep your eye directly vertical above the eyepiece. If the secondary and main mirrors are correctly set up, the pupil of your eye should appear in the middle of the secondary mirror and the centre markings of the main mirror should be in the middle of your pupil. See for yourself which of the adjustment tabs needs to be moved a little bit in or out in order for the mirrors, your pupil and the centre markings to be lined up correctly. After the alignment the main mirror mounting should be just as far down in the tube as it was before. The more exact the alignment, the better the adjustment of the main mirror. Secure the tabs once again with pegs.

**Step 30** If your pupil is not in the centre of the secondary mirror there may be various reasons:

- 1) The secondary mirror may not be directly under the eyepiece connector. In this instance the secondary mirror holder needs to be pushed in or out of the main body a small amount.
- 2) The secondary mirror is not exactly at 45 degrees to the axis of the main body. In this case only the head or foot tabs of the holder need to be moved.

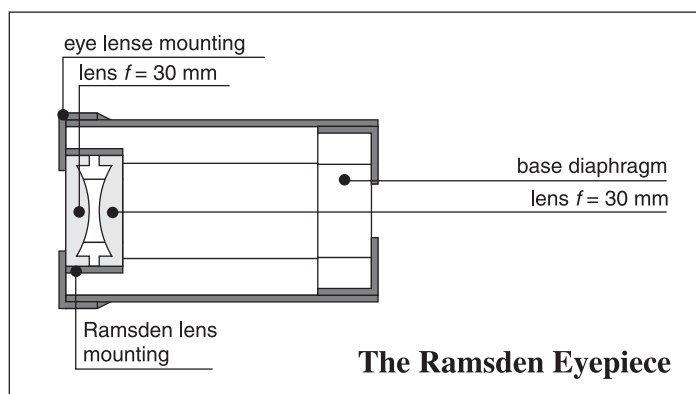

## The Ramsden Eyepiece

### The eyepieces

The two eyepieces have different focal lengths, namely  $f=15\text{mm}$  and  $f=28\text{mm}$ , so that different magnifications are possible. The magnification is calculated by the focal length of the main mirror divided by the focal length of the eyepiece i.e.  $450/15=30$  and  $450/28=16$ . The lenses made out of acrylic glass are all plano-convex (one side is flat and the other curved outwards).

The 15mm eyepiece consists of two lenses with  $f=30\text{mm}$  and is called a Ramsden eyepiece after its inventor. It can reduce the colour distortions of the eye lens through the second lens called the Ramsden lens. The curved side of this lens is facing the eye lens.

The 28mm eyepiece with three lenses has a particularly good colour correction and fringe focus.

**Step 31** Only three of the five accompanying lenses have the same focal length of  $f=30\text{mm}$ , the fourth has a focal length of  $f=49\text{mm}$  and the fifth  $f=65\text{mm}$ . Because they all look very similar and have the same diameter, you must first establish which lens has which focal length.

Place each lens on printed paper with the curved side down. Raise them slowly off the paper and when the ever increasing magnification suddenly goes out of focus and turns upside down, the distance of the lens from the paper corresponds to its focal length.

**Step 32** Fold and glue the eyepiece shaft 15mm [F1] to form a hexagonal tube, black side inward.

**Step 33** Remove the small disc from the middle of the eye lens mounting for the 15mm eyepiece [F2], resulting in a pupil. Fold the six tabs to the back. Take one of the  $f=30\text{mm}$  lenses and glue it with the flat side to the black unprinted side of the eye lens mounting. Put a little glue on the mounting but not too much and not as far as the edge of the pupil, otherwise it will be squeezed onto the lens when the lens is pressed on the card. Place the lens exactly central over the pupil. Leave to dry.

**Step 34** Remove the Ramsden lens mounting [F3]. This is a narrow strip of card. Fold all the grooves to the back and glue it to form a hexagonal ring. After the eye lens [F2] has dried slide the ring [F3] over the lens. It should sit fairly tightly and touch the lens mounting with its edge on all sides. Remove the ring again, place a few drops of glue around the lens and slide the ring a second time over the lens. Leave to dry.

**Step 35** Now take a second  $f=30\text{mm}$  lens. This is the Ramsden lens. Place it, flat side down on your work surface. Turn the lens mounting upside down and slide the open ring over the Ramsden lens. The curved surfaces of the eye lens and Ramsden lens are now facing each other. Remove the Ramsden lens again, place a few drops of glue around the inside of the ring and slide it once again over the Ramsden lens which, when the glue has dried, should lie flush with the outside edge of the ring. Take care not to get any glue on the surface of the lens. Leave to dry.



**Step 36** Remove the small disc from the centre of the 15mm eyepiece base diaphragm [F4] and fold the six tabs to the front. As a trial run slide the diaphragm, hexagon first, into the end of the eyepiece shaft [F1] which has no grey tab markings. Slide it so far until the tabs are flush with the edge of the shaft. The opening in the diaphragm should be a good 7mm from the edge of the shaft. Glue the diaphragm in this position.

**Step 37** Glue the tabs of the eye lens mounting to the other end of the shaft with the eye lens mounting tabs on the outside covering the grey markings and the eye and Ramsden lenses inside the shaft. Leave to dry.

*The 15mm eyepiece is now finished.*

**Step 38** Fold and glue the eyepiece shaft 28mm [F5] to form a hexagonal tube, black side inward.

**Step 39** Remove the small disc from the centre of the mounting for the Ramsden lens of the 28mm eyepiece [F6]. Fold the six tabs to the front. The shape that results is an open hexagonal "chamber" with walls black on the inside only and a hexagonal "floor" with a hole which is black on both sides. Now take the lens with  $f=49\text{mm}$ . This will be the Ramsden lens. Place it on the outside "floor" of the mounting with the curved side against the hole and directly in the middle. Here you will find marking cuts to help you centre it. Glue it in this position. Leave to dry.

**Step 40** Slide the lens mounting [F6], Ramsden lens first, into the end of the eyepiece shaft [F5] which has the grey tab markings, until the mounting tabs are flush with the edge of the shaft. Glue the mounting in this position.

**Step 41** Remove the small disc from the centre of the eye lens mounting [F7] and fold the six tabs to the back. Take the last lens with  $f=30\text{mm}$ , this is the eye lens of the 28mm eyepiece. Glue it with its flat side against the unprinted black surface of the eye lens mounting centring it exactly over the pupil. Take care once again that no glue will be squeezed into the centre of the lens when it is pressed on the card.

Leave to dry.

**Step 42** Place the eye lens mounting at the same end of the eyepiece shaft as the Ramsden lens mounting. The curved sides of the eye lens and Ramsden lens are thus facing each other. Glue the tabs of the eye lens mounting to the eyepiece shaft.

**Step 43** Remove the centre disc from the mounting for the Huygens lens of the 28mm eyepiece [F8] and fold the six tabs to the front, so that you have an open, hexagonal, black, chamber. Take the lens with  $f=65\text{mm}$ . This is the Huygens lens. Glue it with the curved side against the outside of the chamber floor, once again, exactly centred over the pupil. Leave to dry.

**Step 44** Slide the mounting [F8], lens first, into the open end of the eyepiece shaft [F5] so far that the tabs are flush with the edge of the shaft. Glue in this position.

Now all the optical components of the telescope are finished and you can try out the different eyepieces. They should be able to move easily in the eyepiece connector but also be able to remain stationary in any position. If necessary you can glue small pieces of paper to the inside of the connector to create a little bit more friction.

Note for those wearing glasses: It may be necessary in some cases to shorten the eyepieces so that they can be pushed further into the eyepiece connector.

The image is focused by moving the eyepiece on the eye piece connector. For nearer terrestrial objects it must be pulled out further than for astronomical objects. Amazingly one can no longer see the secondary mirror in the image. One can explain this because the light from a far distant object coming through the telescope opening falls on every single point of the main mirror in the same way and from there is directed onto the secondary mirror. If part of the opening is covered, as is the case with the secondary mirror, the image remains unchanged. But it becomes somewhat darker because now only part of the main mirror is being used for gathering the light.

**WARNING:** Never point your telescope at the sun without the sun-filter on it.

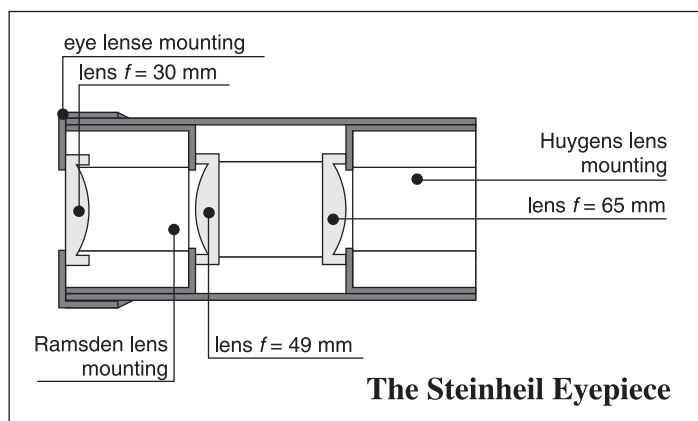

## The Sights

In order to be able to point the telescope quickly to a particular object there are two sights that are known by the technical term "diopter".

**Step 45** Remove the small squares from the two halves of the front sight [G1]+[G2]. Fold the foot tabs to the front and glue both halves together with the unprinted sides facing. After drying, glue the foot tabs of the finished sight onto the marked position in the middle of the mirror segment not far from the main mirror.

**Step 46** Repeat with the two halves of the rear sight [G3] and [G4] and glue them onto the marked position in the middle of the sight segment of the main body.

**Warning:** Never look at the sun through the sights.

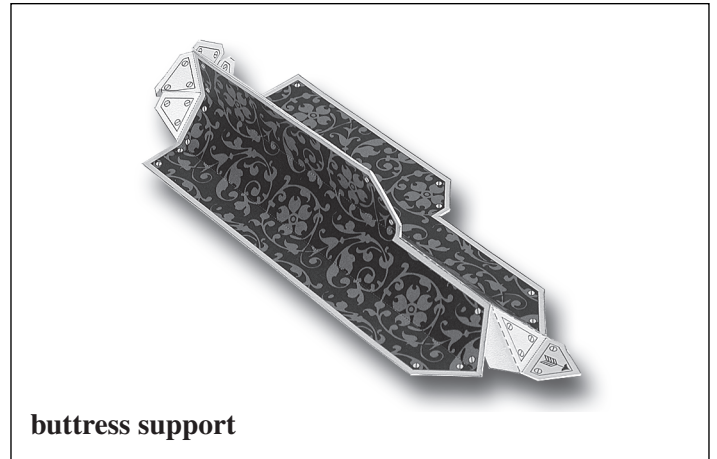

## The Mounting

With every hand held telescope with over 8-10 times magnification, the image is unsteady because the small movements of the arm and hand are magnified. Therefore the main body of this telescope is fixed to a table mounting. It is called a Dobson mounting after its inventor. It is also called an azimuthal mounting and allows the main body to be rotated horizontally by 360 degrees and vertically by over 90 degrees. It consists of a base plate, right and left supports (which are connected via a bridge) and their lateral supports. The semi-circular cut-outs at the top of the supports are the holders for the axles that can be found on either side of the telescope. The degree scales on the axle covers show the angle of inclination between the axis of the telescope and the base.

**Step 47** Glue the unprinted sides of the top and bottom of the base plate [H1] and [H2] together. Press the base plate whilst drying to ensure it is flat.

**Step 48** Fold the foot tabs and the inner half of the bridge of the inner right-hand support [J1] to the front.

**Step 49** Fold the two foot tabs of the outside right-hand support [J2] to the front and glue it exactly on the back of the inside support [J1]. The inner half of the bridge and the tabs remain unglued. Make sure it dries flat.

**Step 50** Repeat for the left hand side supports [J3] and [J4] which are mirror images of the right hand side. Assemble in the same way.

**Step 51** Place the two supports next to each other so that the unprinted halves of the bridge are uppermost and butt neatly up against each other without any gap. Join them with a piece of sticky tape. This joined inner side of the bridge should now be identical to the outside front of the bridge [J5] (without its glue tabs).

**Step 52** Position the two supports on the markings of the base plate [J1]+[J2] with the foot tabs spread apart. The unprinted side of the bridge is facing outwards as are the grey markings on the two supports. Position the supports so that they are parallel to each other and centred on the base plate. The foot tabs are equidistant to the edge of the base-plate and only the markings for the front of the bridge remain open. Glue in this position.

**Step 53** Bend the foot tabs of the front part of the bridge [J5] to the front and the two side tabs to the back. Glue it to the unprinted side of inner bridge. The foot tabs should butt up to the foot tabs of the side supports and be glued into position. The side tabs should also be glued to the side supports.

**Step 54** Take the front piece of the right hand side butterfly support [K1] and fold the two grey tabs and the triangular tab, to which the smaller tab is attached, to the back. All the other folds are to the front. Fold all the grooves of the rear piece of the right hand side butterfly [K2] to the front.

**Step 55** The folds divide [K2] into 3 parts, one of which is shorter than the others and has a stepped top. [K1] has an identical mirror image part with a small grey area at the bottom. These two should be glued together back to back keeping the foot tabs unglued. The long tab on the front piece should be glued to the back of the rear piece. Finally fold the two sides outwards so they make a 60 degree angle between them and glue the tab on the small triangular cover piece to the back of the rear piece leaving the pointer triangle free (see photograph).

**Step 56** After drying, try to position the right-hand butterfly support without any glue against the right hand support. The foot tabs should fit exactly over

the markings and butt firmly up against the tabs of the right hand support without any gaps. The buttress support should cover the glue markings on the side support and the pointer on the triangle should line up with the lowest point of the axle bearing. Glue the buttress support into this position.

**Step 57** Repeat with the front and rear parts of the left-hand side buttress support [K3] and [K4]. They are mirror images of the right hand side but otherwise identical. Glue into place on the left-hand side support.

### The Eyepiece Storage Holders

*Because only one eyepiece at a time is used, you need somewhere to store the other eyepiece along with the cover for the eyepiece connector.*

**Step 58** Fold all the grooves of the neck of the eyepiece connector cover [B4] to the back and glue it to form a hexagonal pipe. Then glue the tabs of the neck to the eyepiece connector cover [B5]. Slide the finished cover into the eyepiece connector to protect the secondary mirror from dust.

**Step 59** Remove the right eyepiece holder [L1] and fold all folds to the back except for the small tab with the screws which folds to the front. Hold it with the chamfered end of the tabs uppermost and glue the tab with the screw heads to the appropriate mark on the right hand support. The tab at the other end is glued to the buttress support.

**Step 60** Repeat with the other eyepiece holder [L2] on the other side.

**Step 61** Now carefully place the axles of your telescope into the axle bearings of the supports. Do not disturb the paper-clips on the mirror holder. The end of the body with the main mirror should be at the open side of the mounting support and the eyepiece should be slanted on top just like the colour cover picture of the kit. If you have determined after several observations with the eyepieces that the basic adjustment of the main mirror has given you a sufficiently good image you can skip the next section on "fine adjustment" and proceed straight to the final assembly in step 65.

### Fine Adjustment – Optional

*When magnified, planets appear as small discs but stars remain points of light, however much you magnify them. The quality of a telescope is shown by the appearance of these points of light and one can use them to optimise the image of this telescope, of course only within the technical limits of a cardboard construction. If you are not happy with the result of the basic adjustment of the telescope, in particular with the view of a star or other far distant points of light, you can try to improve it with the following steps. You will need a steady hand and not little patience, because the finer the adjustment the smaller the corrections that are needed, and sometimes it will be necessary to adjust the adjustment of an adjustment...*

**Step 62** To achieve the optimal adjustment of the telescope you have to point it at a star, only it is difficult to make the adjustments in the dark. In order to work in daylight you need an artificial star in the form of a Christmas tree ball or similar hanging up about 40m away with a dark background for best results. If you look at the ball with the Sun behind you, you see the Sun's reflection in the surface of the ball as a point of light. You don't need the sun-filter to look at this because it is so small.

**Step 63** Point the telescope at the Christmas tree ball with the 28mm eyepiece to start with and get the point of light in the centre of the field of view. Check whether it remains a point of light after carefully focussing the eyepiece. If the light is smeared out to one side then the main mirror must be adjusted very slightly to correct this and obtain the best point. Check that you are happy with the results from the other eyepiece.

**Step 64** In order to be absolutely sure you can check the telescope again at night by observing a star or distant point of light. Do not forget however that you can not expect quite the same image quality from a hand-built cardboard telescope with acrylic lenses as you would expect from a much more expensive factory-made optical precision instrument.

### Final Assembly

*After completion of the basic or fine adjustment the mirrors can now be permanently fixed and the last card pieces glued on.*

**Step 65** Glue the secondary mirror holder [D1] in its final position. Do this by removing one of the 4 paper clips, lifting the tab and applying glue underneath it and then fixing the tab back with the paper-clip. Check again as in step 29 to make sure the image through the eyepiece connector is still in the middle of the secondary mirror in case any slight adjustments are needed to the tab before the glue dries. Repeat this for the remaining three tabs.

**Step 66** Remove the body opening-cap [D2] and fold the tabs to the back. Fit it over the opening of the main body and glue the tabs to the outside of the tube directly in front of the secondary mirror.

**Step 67** Glue the tabs of the main mirror holder into place. Release one tab at a time and glue it into place, replacing the paper clip until dry. If you want you can glue the tab with two spots of glue only so that, if necessary, you can replace the main mirror or readjust its position later. Check through the eyepiece that everything is still in place and then fix the next but one tab in the same way. Repeat for the next but one again and then fix the remaining three tabs. Allow to dry thoroughly.

**Step 68** Remove the body end-cap [E3] and fold the tabs to the back. Check once more that the mirror is in the right position and then cut off the adjusting handles protruding from the body. Fit the end cap onto the end of the main body and glue the tabs to the outside of the tube behind the main mirror. Again you can use spots of glue so that you can remove it later if required.

### Congratulations!

**You are now ready for "First Light" as astronomers call their first observations with a new instrument.**

*We wish you many interesting hours with your home-built reflecting telescope that is perhaps only the first step towards a bigger instrument. Please let us know of any interesting experiences that you may have during construction or use that we may possibly incorporate into future designs or publish in the internet. We look forward to hearing from you.*

### Tips for using your Reflecting Telescope

- 1) The image of a mirror telescope is inverted but you can still use it to look at terrestrial objects. Use the sights to line up the object and focus it with the eyepiece.
- 2) To observe sunspots you must have the sun-filter (No. 210.NSF). Do not use the sights to point the telescope at the sun but move the telescope body until the shadow of the rear sight completely covers the front sight. The number of sunspots follows a regular cycle of about 11 years and the next maximum will probably be in 2011.
- 3) The most rewarding object for night time study is undoubtedly the moon. The craters can be best seen with a waxing or waning moon in the vicinity of the "shadow line" where the sunlight grazes the moon's surface, creating pronounced shadows.
- 4) With careful adjustment of the mirror you can also see Jupiter's moons and indications of Saturn's ring.